

GRAVITI®BLOCK

Permeability Flow Rate

- 12,500 L / hr / m².

- 100 Year Design Life.

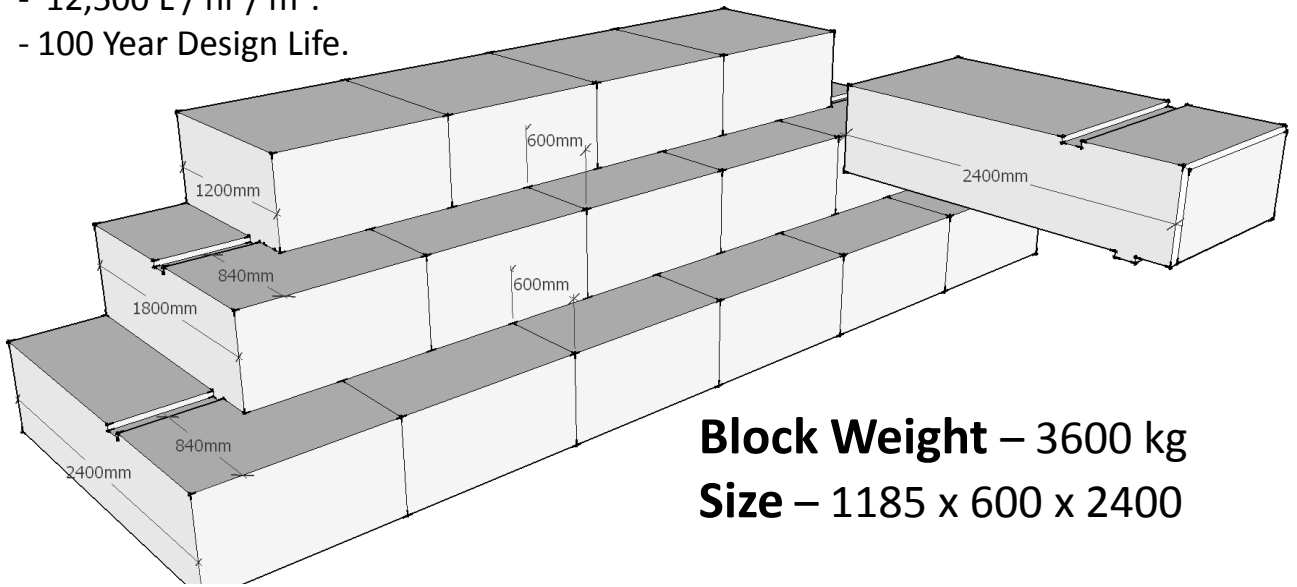

Block Weight – 3600 kg

Size – 1185 x 600 x 2400

Plan View

End View

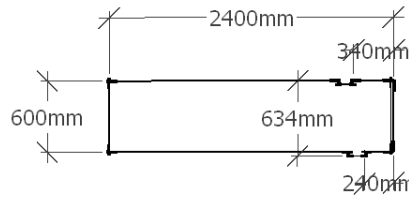
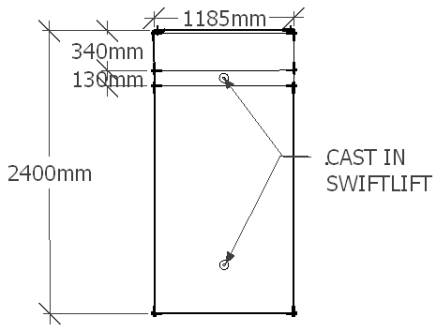

Standard Block
100 step back
Each Course

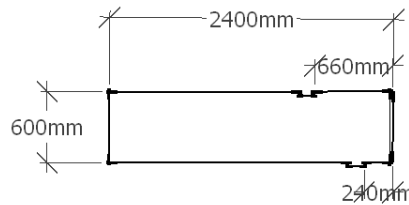
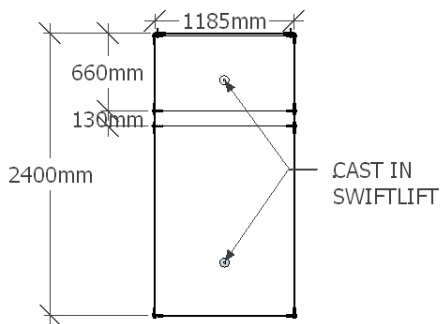

Key Set For
420 step back
Each Course

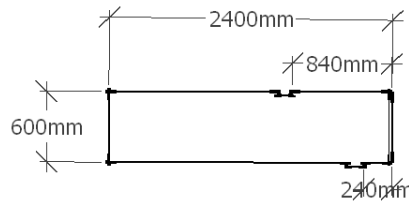
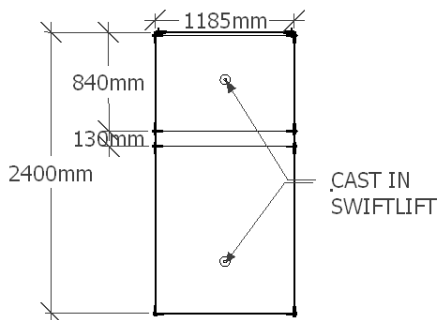

Key Set For
600 step back
Each Course